



HDC-900-GPT OPERATION & SERVICE MANUAL

Towable Hydraulic Drum Crusher



VESTIL MANUFACTURING CORP.

2999 NORTH WAYNE STREET, P.O. BOX 507, ANGOLA, IN 46703

TELEPHONE: (260) 665-7586 –OR- TOLL FREE: (800) 348-0868

FAX: (260) 665-1339

WEBSITE: WWW.VESTILMFG.COM EMAIL: SALES@VESTIL.COM

Receiving Instructions: Each unit is thoroughly inspected prior to shipment. However, the compactor may sustain damage during transit. After the carrier delivers the product, remove all packaging material and inspect the unit for damage. If you notice damage, make note of it on the SHIPPER RECEIPT and FILE A CLAIM WITH THE CARRIER IMMEDIATELY.

Table of Contents

Safety Principles.....	2
Safe Operation Recommendations	2
Product Introduction	3
Functions Tests & Inspections.....	15 - 16
Preparing for Operation	16
Operation.....	16
Inspections & Maintenance.....	19
Label Placement Diagram.....	20 - 21
Limited Warranty.....	22

Table of Figures

Fig. 1 Hydraulic System Diagram.....	4
Fig. 2 Electric System Diagram.....	5
Fig. 3 Parts Diagrams.....	6 - 14
Fig. 4 Emergency Stops.....	15
Fig. 5A & 5B Oil Reservoir.....	15
Fig. 6 Drum enclosure.....	15
Fig. 7 Compactor orientation control.....	16
Fig. 8 Stabilizing jacks storage & use.....	16
Fig. 9 Gasoline motor.....	17
Fig. 10 Auto cycle valve.....	17
Fig. 11 Hydraulic oil fill cap.....	18

SAFETY PRINCIPLES

This manual classifies personal injury risks and situations that could lead to property damage with SIGNAL WORDS. These signal words announce an associated safety message. The reader must understand that the signal word chosen indicates the seriousness of the described hazard.



DANGER Identifies a hazardous situation which, if not avoided, WILL result in DEATH or SERIOUS INJURY. Use of this signal word is limited to the most extreme situations.



WARNING Identifies a hazardous situation which, if not avoided, COULD result in DEATH or SERIOUS INJURY.



CAUTION Indicates a hazardous situation which, if not avoided, COULD result in MINOR or MODERATE injury.



NOTICE Identifies practices likely to result in product/property damage, such as operation that might damage the HDC.

Safe Operation Recommendations:



DANGER To avoid the risk of electrocution, DO NOT contact electrified wires with any part of the crusher or operate the HDC close to electrified wires (or other sources of electrical energy). Always inspect the area where you will use the machine *prior to* operation. Pay particular attention to overhead hazards; the maximum height of this product (when the crushing ram is fully raised), is 8 ft. 8in (~2.6m) above the ground.



WARNING *Failure to read and understand the instructions included in this manual before using or servicing the drum crusher constitutes misuse of the product.* Improper use might result in serious personal injuries and/or could damage the crusher. To minimize the possibility of injury, ALL persons who might operate, perform maintenance on or service the crusher must read, understand and apply the following instructions:

- **Read the *entire* manual before you use or transport the compactor for the first time and as necessary thereafter.**
- Test and inspect the crusher according to the “Functions Tests and Inspections” instructions on p. 15-16 before each use to confirm normal function and condition. DO NOT use the crusher unless it is in normal condition.
- DO NOT continue use the crusher if it makes unusual noise(s) during operation. DO NOT use the crusher if you observe any damage to the load-supporting elements like, but not limited to, the I-beam welded to the bottom of the drum enclosure, stabilizing jacks or the (jack) mounts on the trailer frame for the stabilizing jacks, wheels, or the (trailer) tongue jack. If you notice damage, immediately tag the unit “Out of Service” and inform the person(s) responsible for maintenance of the problem. DO NOT use the crusher until it is again in normal condition.
- DO NOT use this device to transport people or material. Even if traveling a very short distance, do not allow people to ride on the crusher.
- **DO NOT attempt to crush material other than empty barrels. DO NOT exceed the crushing capacity of the device, which can crush steel barrels of up to 55 gallon volume.** Always center the barrel under the crushing platen.
- DO NOT park or use the crusher on inclined (sloped) surfaces. Only operate the unit on flat, level surfaces.
- DO NOT leave the crusher unattended with an enclosed load. Always remove any drum (or crushed drum) from the drum enclosure before leaving the HDC unattended.
- DO NOT leave the crusher unattended until it is put into the storage configuration: 1) retract the crusher mechanism (tilt it back onto the trailer); 2) chock the wheels; and 3) remove the key from the motor.
- DO NOT modify this device without prior written authorization from Vestil. Unauthorized modifications may make the crusher unsafe to use.
- **DO NOT** attempt to resolve any problems with the product unless you are certain that it will be safe to use afterwards.

PRODUCT INTRODUCTION

Thank you for purchasing a towable hydraulic drum compactor, model HDC-900-GPT made by Vestil Manufacturing Corporation (“Vestil”). Our compactors are durable, high-quality products that combine portability and power. To protect operators, each HDC incorporates several standard safety features: 1) crushes drums within an enclosure; 2) drum enclosure rotates under hydraulic power between a horizontal position for transport and a vertical position for use; 3) a siren and rotating amber light activate as the compactor pivots towards the use position (or back onto the trailer for transport); 4) safety switch on the drum enclosure door to prevent operation while the door is open (the door must be closed and latched for the crusher to operate); and 5) two (2) emergency stop buttons--1 on the right side of the drum enclosure, and another next to the motor--to immediately shut off the motor if an issue arises during use.

The electrical system is energized by one 12 volt, 70 amp-hour battery. The battery provides power to key start the motor. It supplies electricity for a thermostatically activated fan that works to prevent the hydraulic oil from becoming too hot. The battery also powers the siren and amber warning light system.

Other relevant specifications appear in the table below:

<u>Model</u>	<u>Net Weight</u>	<u>Pounds of Crushing Force</u>	<u>Overall Length</u>	<u>Overall Height</u>
HDC-900-GPT	3,200 pounds (1,455kg)	38,000 pounds (19 tons; 17.3 metric tons)	Minimum length (in transport position on trailer) = 11ft. 4in. or~3.5m Maximum length (while tilting crusher) = 12ft 1in. or ~3.7m	Minimum overall height (in transport position on trailer) = 4 ft. 8in. or ~1.4m Maximum height (crusher in operating position and ram fully raised) = 8 ft. 8in or ~2.6m

FIG. 1: Hydraulic System Diagram

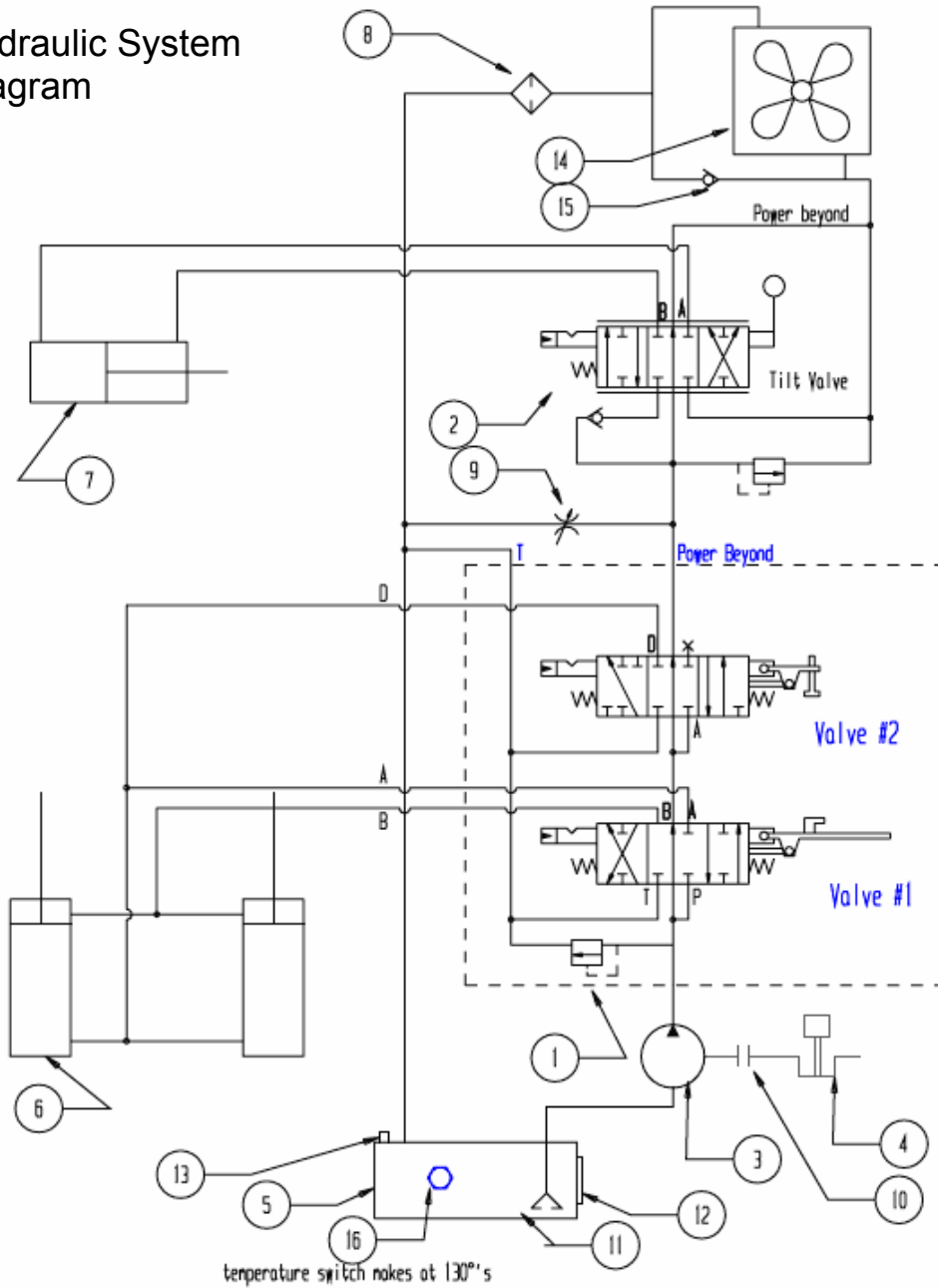

Item No.	Part No.	Description	Quantity
1	HC-Y-BJ01	HC-Y-BJ01 auto-cycle valve assembly	1
2	RD 2508-T4-EF-A1	RD 2508-T4-EF-A1 manual directional valve	1
3	SP20805A9H2R	SP20805A9H2R hydraulic pump	1
4	356447-00676	18HP motor	1
5	N/A	Reservoir	1
6	N/A	Drum crushing cylinders: 80mm (diameter) x 36in. (stroke)	2
7	99-021-923	Compactor tilting cylinder	1
8	SPE-15-10	Threaded filter element	1
9	N/A	Pneumotrol needle valve	1
10	LB152825A	Pump motor adapter	1
11	SS10RV3	Pump strainer	1
12	5054-D	Tank end cover	1
13	AB-1163S	Filler breather	1
14	DCS-16-12VLT	Oil cooler	1
15	CV10-25	Check valve	1
16	PDTF-130°F-R-8MN-C-FL18	Temperature switch	1

FIG. 2: Electrical system diagram

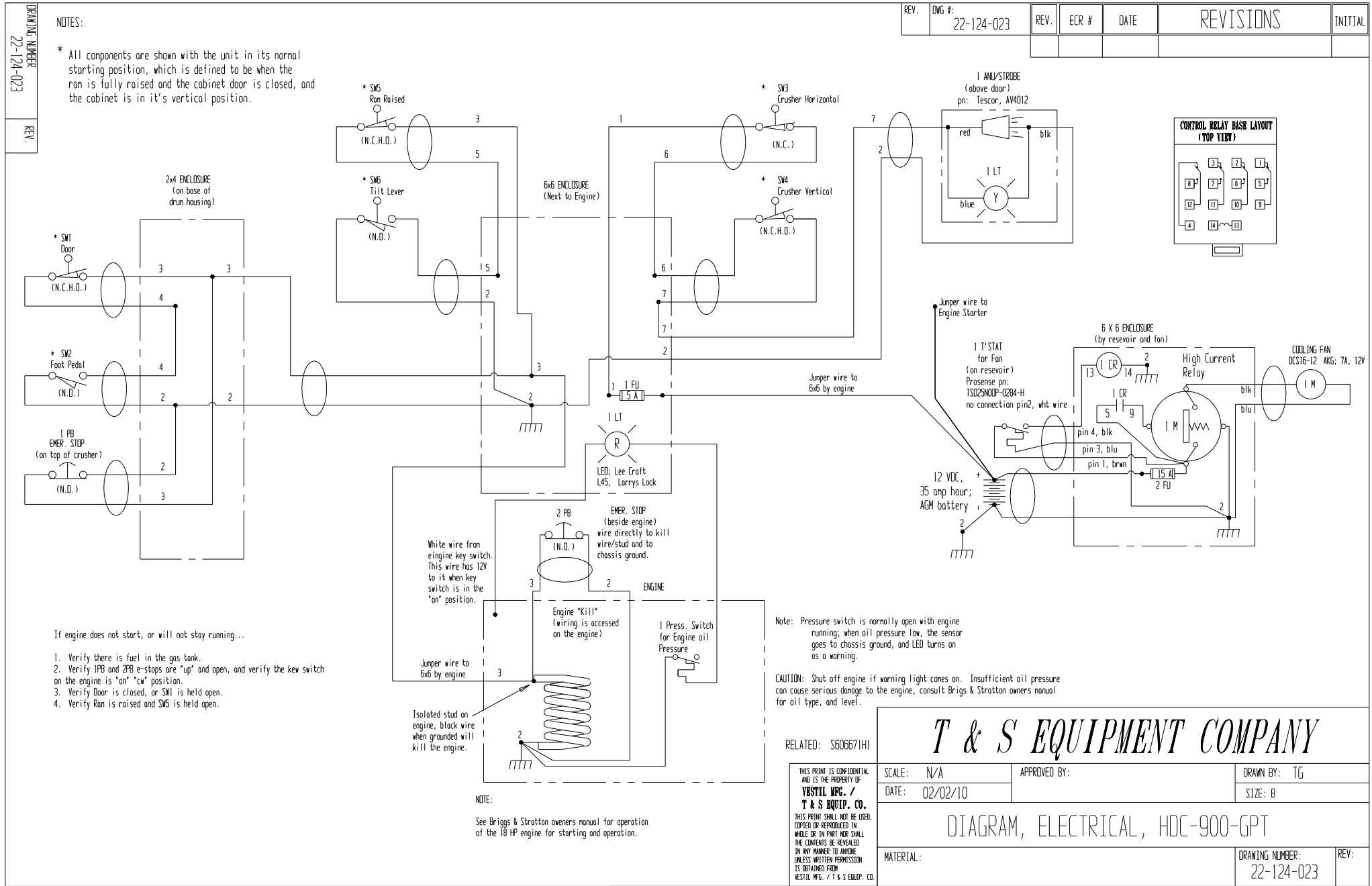

REV.	DWG #:	REV.	ECR #	DATE	REVISIONS	INITIAL

HDC-900-GPT

MOBILE GASOLINE POWERED DRUM CRUSHER

PARTS LIST

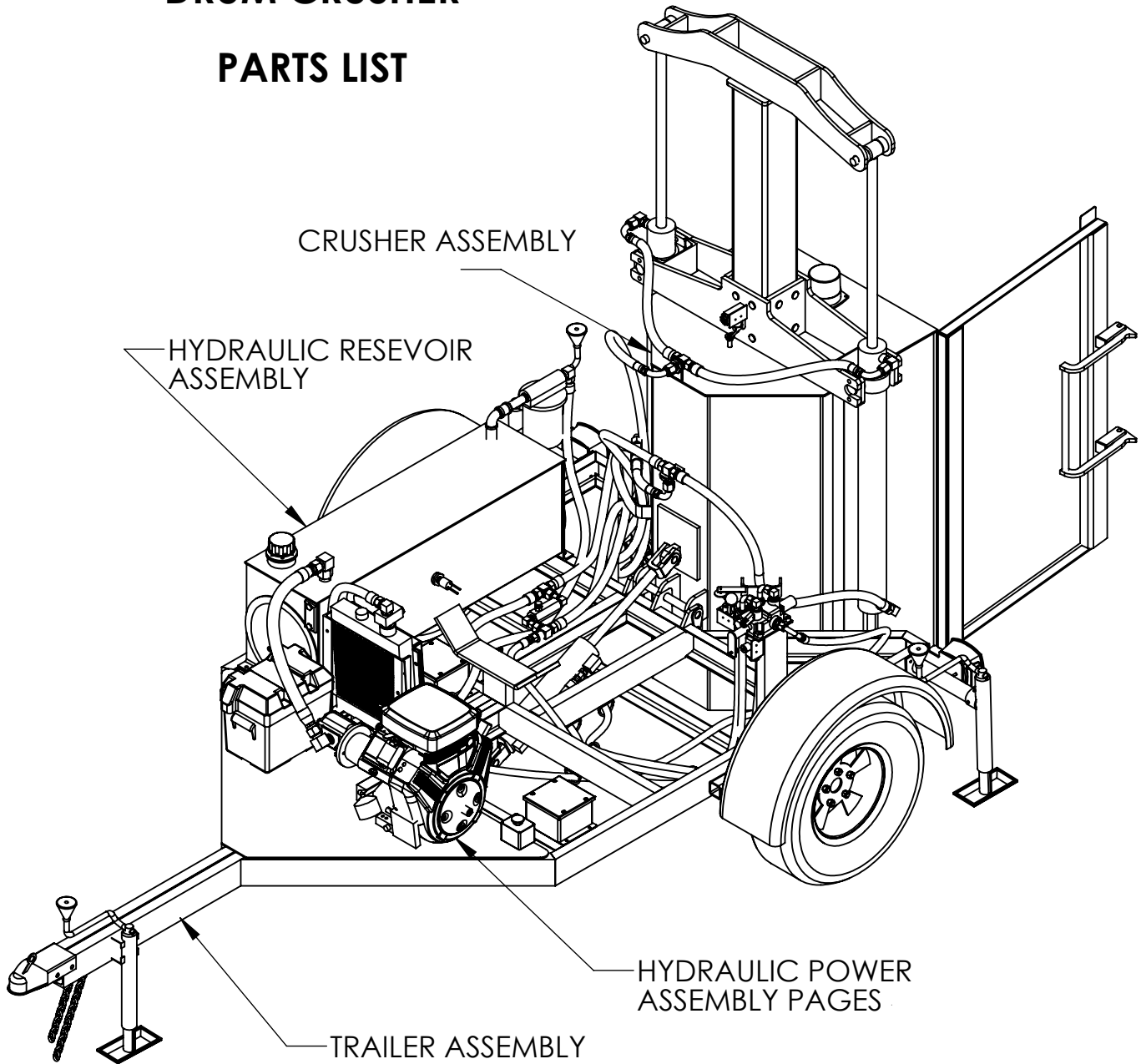

THE INFORMATION CONTAINED IN THIS DRAWING IS THE SOLE PROPERTY OF VESTIL MANUFACTURING CO. ANY REPRODUCTION IN PART OR AS A WHOLE WITHOUT THE WRITTEN PERMISSION OF VESTIL MANUFACTURING CO. IS PROHIBITED.

REMOVE ALL BURRS AND SHARP EDGES		
CONCENTRIC	.006 TIR	.060 TIR
ANGLES	+/- 0° 30'	+/- 1° 0'
DECIMALS	x.xxx +/- .005 x.xx +/- .010 x.x +/- .025	+/- .015
FRACTIONS	+/- 1/32	+/- 1/16
TOLERANCE	MACHINE	WELDMENT

Vestil Manufacturing Co.

SCALE: NTS	APPROVED BY:	DRAWN BY: J.YOUNG
DATE: 06/30/11		SIZE: A

HDC2 PARTS LIST

MATERIAL:	DRAWING NUMBER:	REV:
-----------	-----------------	------

REV.	DWG #:	REV.	ECR #	DATE	REVISIONS	INITIAL

REV.
*

ITEM NO.	PartNo	DESCRIPTION	QTY.
1	HDC2 TRAILER	TRAILER FOR MOBILE DRUM CRUSHER	1
2	145WS205BC-1	WHEEL AND TIRE	2
3	#10 TORFLEX	AXLE	1
4	80050	COUPLER	1
5	TJ-06	SIDE MOUNT TRAILER JACK	1
6	HDC2 1097	JACK MOUNT	2
7	TJ-F3	TUBE MOUNT JACK	2
8	540	LIGHT KIT	2
9	36224	LUG NUT	10

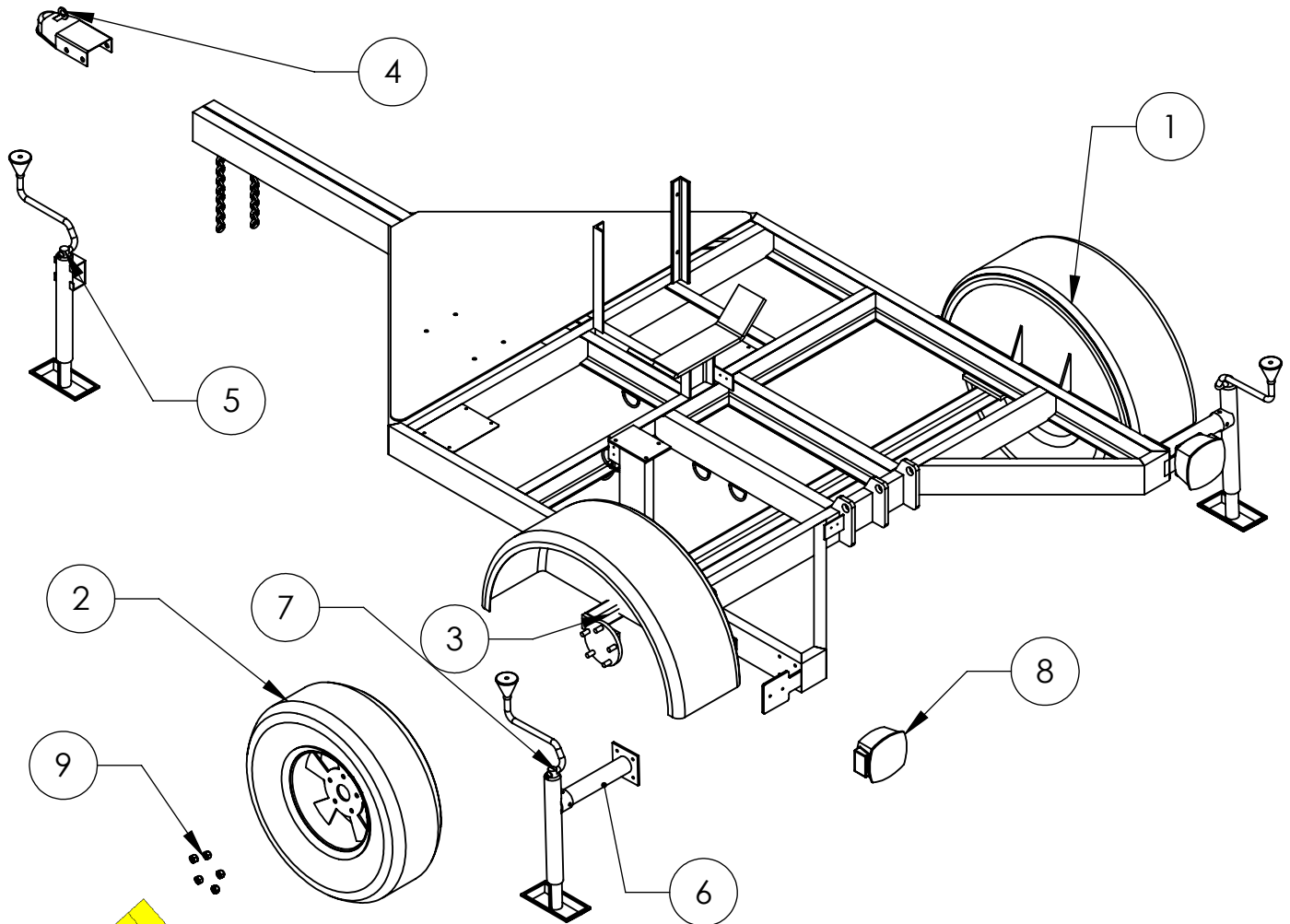

THE INFORMATION CONTAINED IN THIS DRAWING IS THE SOLE PROPERTY OF VESTIL MANUFACTURING CO. ANY REPRODUCTION IN PART OR AS A WHOLE WITHOUT THE WRITTEN PERMISSION OF VESTIL MANUFACTURING CO. IS PROHIBITED.

REMOVE ALL BURRS AND SHARP EDGES		
CONCENTRIC	.006 TIR	.060 TIR
ANGLES	+/- 0° 30'	+/- 1° 0'
DECIMALS	x.xxx +/- .005 x.xx +/- .010 x.x +/- .025	+/- .015
FRACTIONS	+/- 1/32	+/- 1/16
TOLERANCE	MACHINE	WELDMENT

Vestil Manufacturing Co.

SCALE: NTS APPROVED BY: DRAWN BY: J.YOUNG
DATE: 06/30/11 SIZE: A

HDC2 TRAILER PARTS LIST

MATERIAL: DRAWING NUMBER: REV:

REV.	DWG #:	REV.	ECR #	DATE	REVISIONS	INITIAL

REV: *

ITEM NO.	PartNo	DESCRIPTION	QTY.
1	5054-D	12" END COVER KIT	2
2	AB-1164-S	FILLER BREATHER	1
3	FA1200-00	FILTER HEAD SPIN ON	1
4	ZC10700	FILTER SPIN ON	1
5	GS-3	SIGHT GAUGE	2
6	1 ST EL	1" STREET EL	1
7	3/4 ST EL	3/4" STREET EL	1
8	3/4 X 4 SCH40	3/4" PIPE NIPPLE	1
9	2502-16-16	1" JIC X 1" F NPT	1
10	SS10RV3	SUCTION STRAINER	1
11	3/4 COUP	3/4" PIPE COUPLING	2
12	5406-12-04	REDUCER BUSHING	1
13	16GMV-16FJX-16FJX-33	SUCTION HOSE	1
14	6801-16-10	SAE X JIC 90	1
15	HDC2 1102	30 GALLON RESERVOIR	1
16	TSD25N-0P-0284	TEMPERATURE SWITCH	1

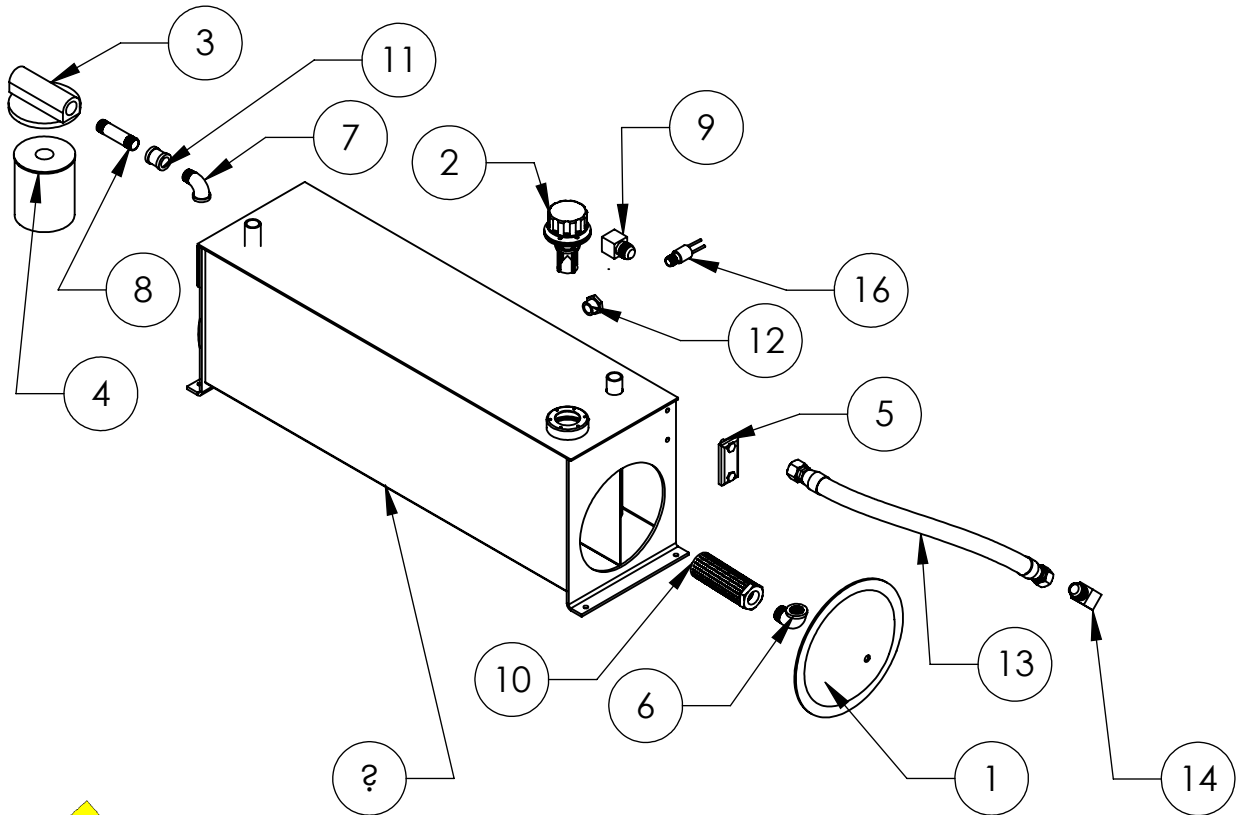

THE INFORMATION CONTAINED IN THIS DRAWING IS THE SOLE PROPERTY OF VESTIL MANUFACTURING CO. ANY REPRODUCTION IN PART OR AS A WHOLE WITHOUT THE WRITTEN PERMISSION OF VESTIL MANUFACTURING CO. IS PROHIBITED.

REMOVE ALL BURRS AND SHARP EDGES		
CONCENTRIC	.006 TIR	.060 TIR
ANGLES	+/- 0° 30'	+/- 1° 0'
DECIMALS	x.xxxx +/- .005 x.xxx +/- .010 x.x +/- .025	+/- .015
FRACTIONS	+/- 1/32	+/- 1/16
TOLERANCE	MACHINE	WELDMENT

Vestil Manufacturing Co.

SCALE: NTS APPROVED BY: DRAWN BY: J.YOUNG
 DATE: 06/30/11 SIZE: A

HDC2 RESERVOIR PARTS LIST

MATERIAL: DRAWING NUMBER: REV:

REV.	DWG #:	REV.	ECR #	DATE	REVISIONS	INITIAL

REV.
*

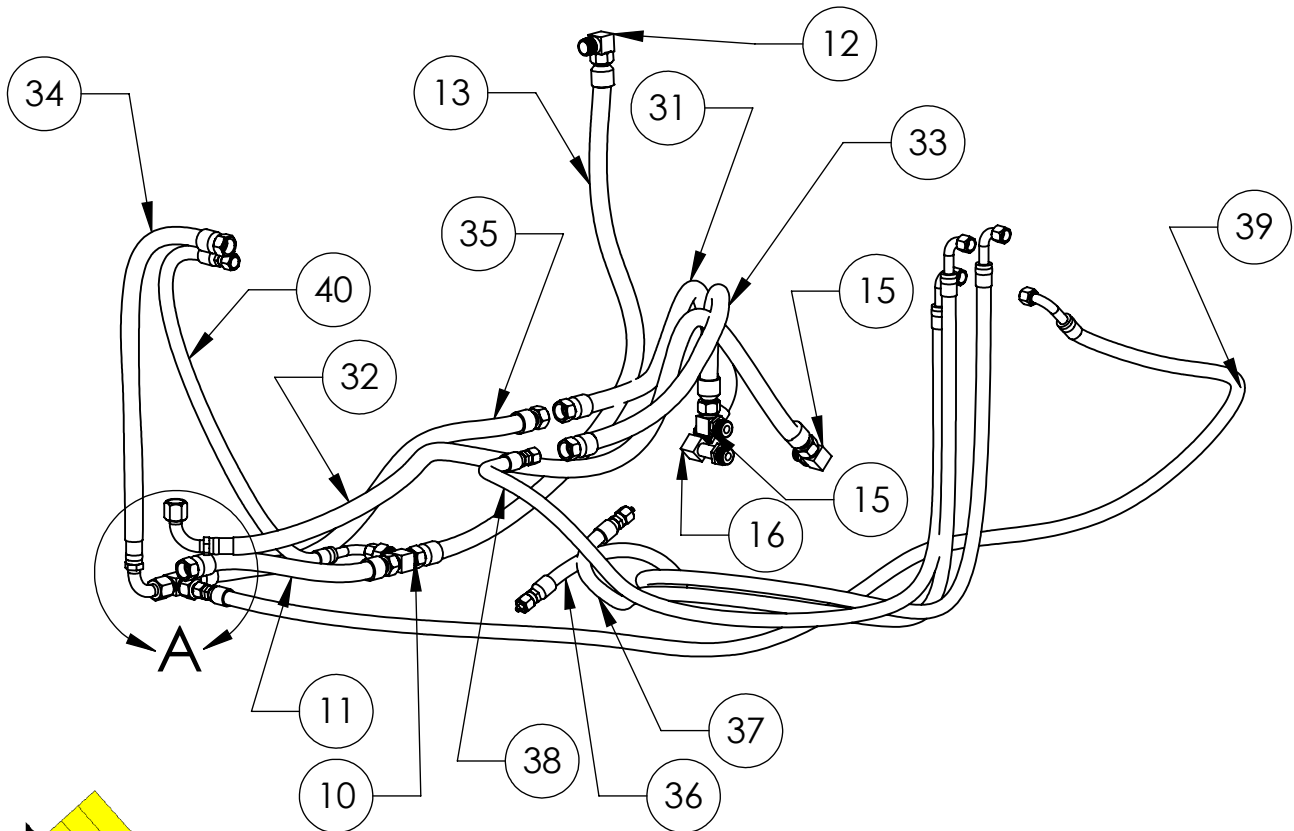
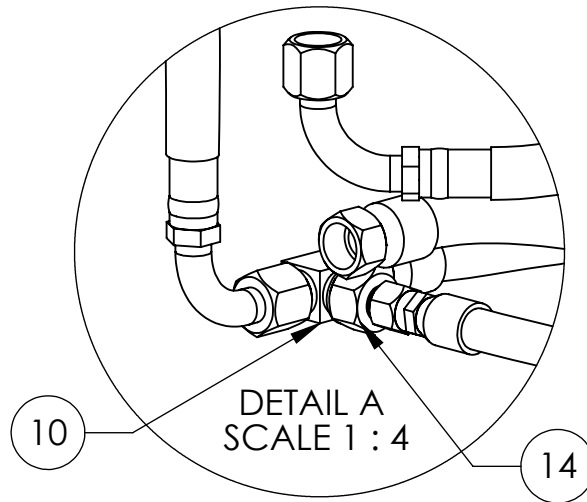

THE INFORMATION CONTAINED IN THIS DRAWING IS THE SOLE PROPERTY OF VESTIL MANUFACTURING CO. ANY REPRODUCTION IN PART OR AS A WHOLE WITHOUT THE WRITTEN PERMISSION OF VESTIL MANUFACTURING CO. IS PROHIBITED.

REMOVE ALL BURRS AND SHARP EDGES		
CONCENTRIC	.006 TIR	.060 TIR
ANGLES	+/- 0° 30'	+/- 1° 0'
DECIMALS	x.xxxx +/- .005 x.xxx +/- .010 x.x +/- .025	+/- .015
FRACTIONS	+/- 1/32	+/- 1/16
TOLERANCE	MACHINE	WELDMENT

Vestil Manufacturing Co.

SCALE: NTS	APPROVED BY:	DRAWN BY: J.YOUNG
DATE: 06/30/11		SIZE: A
HDC2 POWER ASSEMBLY PARTS LIST SHEET 1		
MATERIAL:	DRAWING NUMBER:	REV:

REV.	DWG #:	REV.	ECR #	DATE	REVISIONS	INITIAL

REV.
*

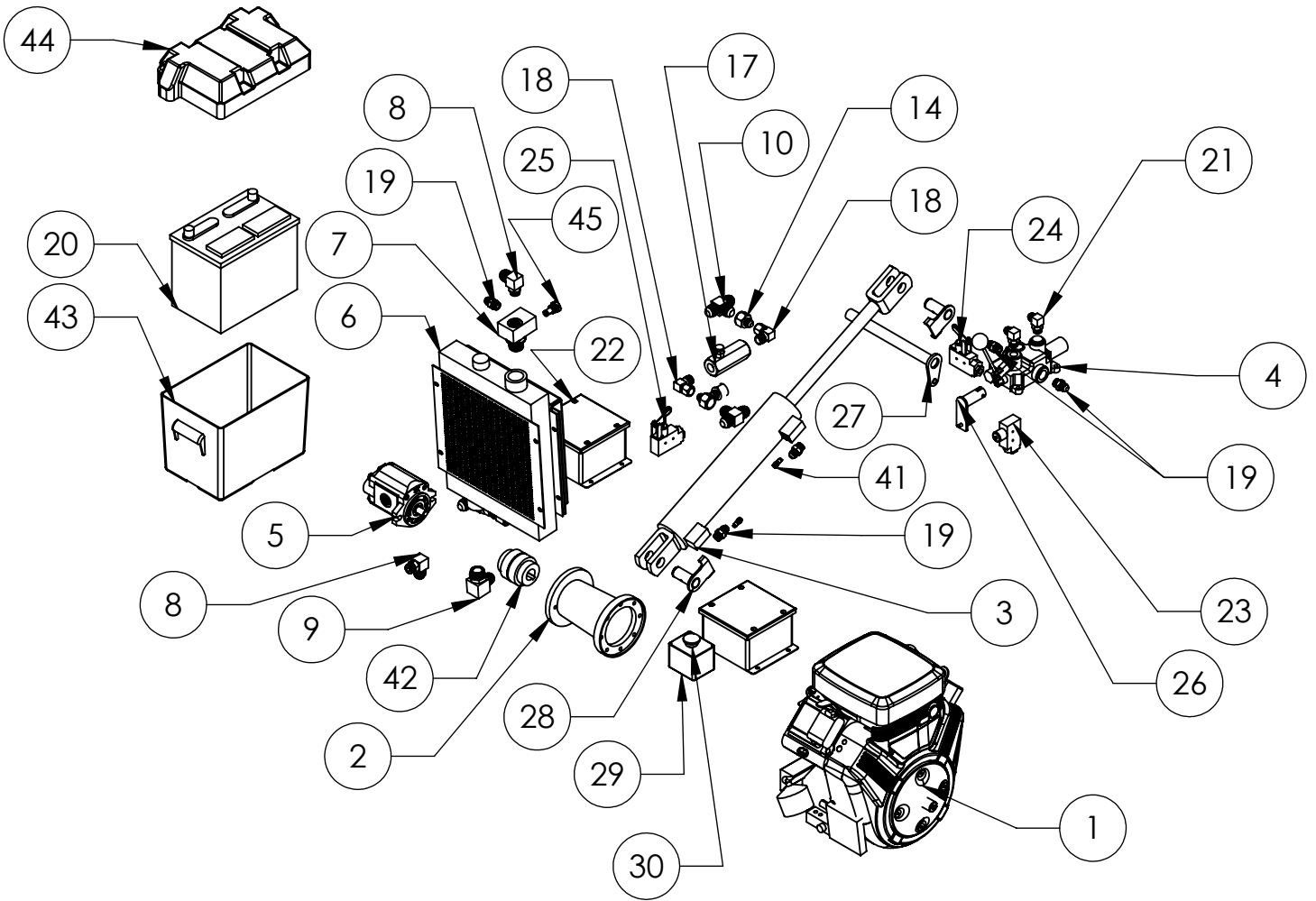

THE INFORMATION CONTAINED IN THIS DRAWING IS THE SOLE PROPERTY OF VESTIL MANUFACTURING CO. ANY REPRODUCTION IN PART OR AS A WHOLE WITHOUT THE WRITTEN PERMISSION OF VESTIL MANUFACTURING CO. IS PROHIBITED.

REMOVE ALL BURRS AND SHARP EDGES		
CONCENTRIC	.006 TIR	.060 TIR
ANGLES	+/- 0° 30'	+/- 1° 0'
DECIMALS	x.xxx +/- .005 x.xx +/- .010 x.x +/- .025	+/- .015
FRACTIONS	+/- 1/32	+/- 1/16
TOLERANCE	MACHINE	WELDMENT

Vestil Manufacturing Co.

SCALE: NTS APPROVED BY: DRAWN BY: J.YOUNG
DATE: 06/30/11 SIZE: A

HDC2 POWER ASSEMBLY PARTS LIST SHEET 2

MATERIAL: DRAWING NUMBER: REV:

REV.	DWG #:	REV.	ECR #	DATE	REVISIONS	INITIAL

ITEM NO.	PartNo	DESCRIPTION	QTY.
1	356447-0066B1	18 HP BRIGGS & STRATTON	1
2	LB152825A	PUMP/MOTOR ADAPTER	1
3	99-021-923	TILT CYLINDER	1
4	RD-2575-T4-ESA1	TILT VALVE	1
5	SP20B06A9H2R	PUMP	1
6	DCS16-12V	AIR COOLER	1
7	S501303	COOLER BYPASS TEE	1
8	6801-12-10	SAE X JIC 90	2
9	6801-12-16	3/4" JIC X 1" SAE 90	1
10	2603-12-12-12	TEE	4
11	12M3K-12FJX-12FJX-17	HOSE,COOLER OUT TO COOLER TEE	1
12	2501-12-12	12JIC X 3/4 NPT ELL	1
13	12M3K-12FJX-12FJX-37	HOSE,COOLER TEE TO FILTER	1
14	2406-12-08	12 FJIC X 8MJIC	5
15	6801-12-12	12JIC X 12SAE	2
16	6801-L-12-12	12JIC X 12SAE90 LONG	1
17	PC5-4	FLOW CONTROL	1
18	6501-08-08	1/2"NPT X 8JIC FSWIVEL	2
19	6400-08-08	08 JIC X 08 SAE	5
20	24DP-550	BATTERY	1
21	2501-08-08 90	08JIC X 08NPT	2
22	01-029-006	6 X 6 X 4 ENCLOSURE	2
23	MJ1 6101	LIMIT SWITCH	1
24	MJ1 6101	LIMIT SWITCH	1
25	MJ1 6101	LIMIT SWITCH	1
26	HDC2 1085	LIMIT SWITCH ACTUATOR	1
27	HDC 1094	PIVIOT PIN	1
28	03-037-005	HINGE PIN ASS'Y (EM)	2
29	8L2PP1A8	PUSH BOTTON BOX	1
30	ZB2-BT4C	E-STOP BUTTON	1
31	12M3K-12FJX-12FJX-45	HOSE, MAIN VALVE TANK	1
32	123K-12FJX-12FJX90-78	HOSE,PUMP TO MAIN VALVE	1
33	12M3K-12FJX-12FJX-50	HOSE,POWER BEYOND	1
34	12M3K-12FJX-12FJX90-28	HOSE, COOLER IN	1
35	12M3K-12FJX-12FJX-29	HOSE,TILT BI-PASS TO COOLER	1
36	8M3K-8FJX-8FJX90-80	HOSE,TILT RAISE	1
37	8M3K-8FJX-8FJX90-62	HOSE, TILT LOWER	1
38	8M3K-8FJX-8FJX90-63	HOSE,TILT PRESSURE	1
39	8M3K-8-FJX8-FJX90-88	HOSE,TILT TANK LINE	1
40	8M3K-8FJX-8FJX90-44	HOSE,COOLER BI-PASS	1
41	ST194-2	PC FLOW CONTROL	2
42	ML100 5/8"-5/32KW X 1 1/8"-1/4KW	SHAFT COUPLING	1
43	BOX-24	BATTERY BOX	1
44	BOX-24	BATTERY BOX LID	1
45	99-153-011	CHECK VALVE	1



THE INFORMATION CONTAINED IN THIS DRAWING IS THE SOLE PROPERTY OF VESTIL MANUFACTURING CO. ANY REPRODUCTION IN PART OR AS A WHOLE WITHOUT THE WRITTEN PERMISSION OF VESTIL MANUFACTURING CO. IS PROHIBITED.

REMOVE ALL BURRS AND SHARP EDGES		
CONCENTRIC	.006 TIR	.060 TIR
ANGLES	+/- 0° 30'	+/- 1° 0'
DECIMALS	x.xxx +/- .005 x.xx +/- .010 x.x +/- .025	+/- .015
FRACTIONS	+/- 1/32	+/- 1/16
TOLERANCE	MACHINE	WELDMENT

Vestil Manufacturing Co.

SCALE: NTS	APPROVED BY:	DRAWN BY: J.YOUNG
DATE: 06/30/11		SIZE: A
HDC2 POWER ASSEMBLY PARTS LIST SHEET 3		
MATERIAL:	DRAWING NUMBER:	REV:

REV.	DWG #:	REV.	ECR #	DATE	REVISIONS	INITIAL

REV.
*

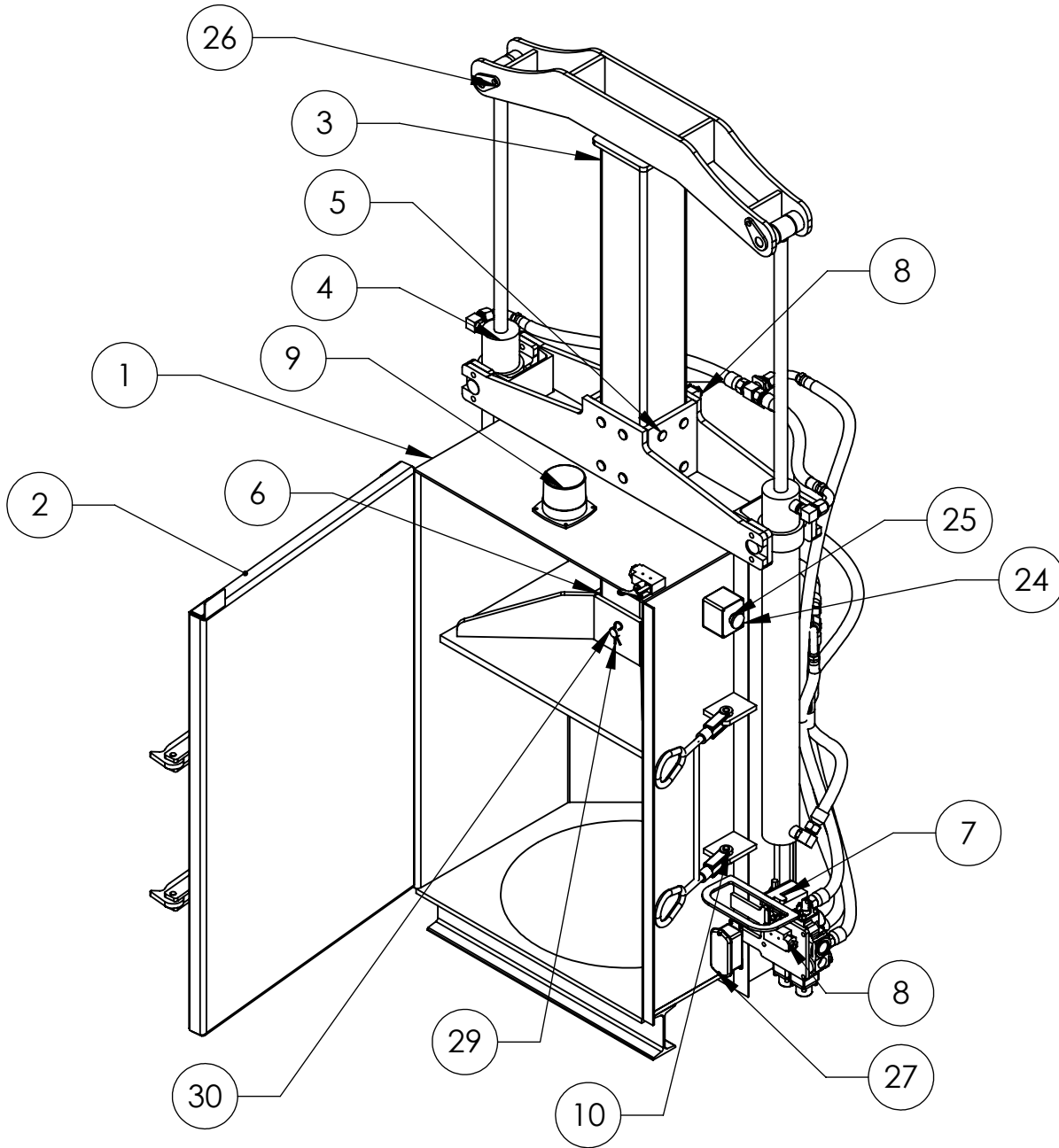

THE INFORMATION CONTAINED IN THIS DRAWING IS THE SOLE PROPERTY OF VESTIL MANUFACTURING CO. ANY REPRODUCTION IN PART OR AS A WHOLE WITHOUT THE WRITTEN PERMISSION OF VESTIL MANUFACTURING CO. IS PROHIBITED.

REMOVE ALL BURRS AND SHARP EDGES		
CONCENTRIC	.006 TIR	.060 TIR
ANGLES	+/- 0° 30'	+/- 1° 0'
DECIMALS	x.xxx +/- .005 x.xx +/- .010 x.x +/- .025	+/- .015
FRACTIONS	+/- 1/32	+/- 1/16
TOLERANCE	MACHINE	WELDMENT

Vestil Manufacturing Co.

SCALE: NTS APPROVED BY: DRAWN BY: J.YOUNG
DATE: 06/30/11 SIZE: A

HDC2 CRUSHER ASSEMBLY PARTS LIST SHEET 1

MATERIAL: DRAWING NUMBER: REV:

REV.	DWG #:	REV.	ECR #	DATE	REVISIONS	INITIAL

REV.
*

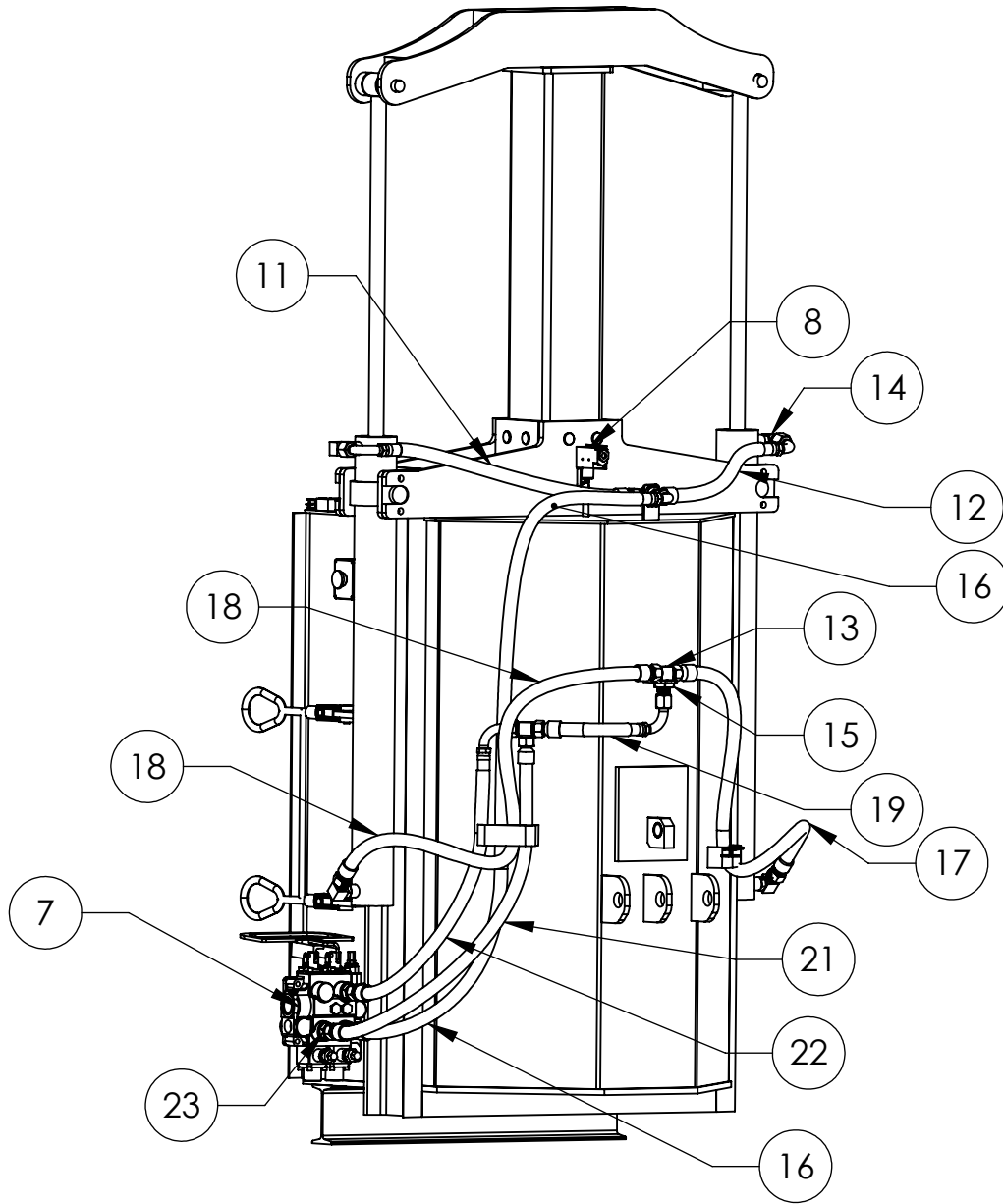

THE INFORMATION CONTAINED IN THIS DRAWING IS THE SOLE PROPERTY OF VESTIL MANUFACTURING CO. ANY REPRODUCTION IN PART OR AS A WHOLE WITHOUT THE WRITTEN PERMISSION OF VESTIL MANUFACTURING CO. IS PROHIBITED.

REMOVE ALL BURRS AND SHARP EDGES		
CONCENTRIC	.006 TIR	.060 TIR
ANGLES	+/- 0° 30'	+/- 1° 0'
DECIMALS	x.xxx +/- .005 x.xx +/- .010 x.x +/- .025	+/- .015
FRACTIONS	+/- 1/32	+/- 1/16
TOLERANCE	MACHINE	WELDMENT

Vestil Manufacturing Co.

SCALE: NTS APPROVED BY: DRAWN BY: J.YOUNG
 DATE: 06/30/11 SIZE: A

HDC2 CRUSHER ASSEMBLY PARTS LIST SHEET 2

MATERIAL: DRAWING NUMBER: REV:

REV.	DWG #:	REV.	ECR #	DATE	REVISIONS	INITIAL

ITEM NO.	PartNo	DESCRIPTION	QTY.
1	HDC2 1010	HDC2 CRUSHER WELDMENT	1
2	HDC2 1105	HDC2 DOOR	1
3	HDC2 1106	HDC2 RAM	1
4	22-021-008	HDC2 MAIN CYLINDER	2
5	HDC2 1026	HDC2 RAM BEARING	16
6	HDC2 1107	HDC2 PLATTEN	1
7	HDC2 1108	HDC2 MAIN VALVE	1
8	MJ1 6101	LIMIT SWITCH	3
9	HDC2 1091	WARNING BEACON	1
10	HDC2 1014	HDC2 DOOR LATCH	1
11	12M3K-12FJX-12FJX90-22R	HDC2 RIGHT RETRACT HOSE	1
12	12M3K-12FJX-12FJX90-22L	HDC2 LEFT RETRACT HOSE	1
13	2703-12-12-12	3/4" JIC BULKHEAD TEE	2
14	6801-12-10	SAE X JIC 90	4
15	306-12	BULKHEAD NUT	2
16	12M3K-12FJX-12FJX90-65	HDC2 HOSE RETRACT TO VALVE	1
17	12M3K-12FJX-12FJX-38L	HDC2 RETRACT HOSE LEFT	1
18	12M3K-12FJX-12FJX-38R	HDC2 RETRACT HOSE RIGHT	1
19	12M3K-12FJX-12FJX-6	HDC2 EXTEND/REGEN HOSE	1
20	2603-12-12-12	TEE	1
21	12M3K-12FJX-12FJX-32-2	HOSE CYL EXTEND REGEN	1
22	12M3K-12FJX-12FJX90-32-3	HOSE,CYL EXTEND	1
23	6400-12-12	12JIC X 12 SAE	3
24	8L2PP1A8	PUSH BOTTON BOX	1
25	ZB2-BT4C	E-STOP BUTTON	1
26	HDC2 1101	HDC2 CYLINDER PIN	2
27	A-402DCS	JUNCTION BOX	1
28	HDC2 1109	HDC2 UPPER LIMIT ROD	1
29	45286	#11 HITCH PIN CLIP, Ø1/8" X 2 5/8 LG	2
30	HDC2 1108	HDC2 PLATEN PIN	1



THE INFORMATION CONTAINED IN THIS DRAWING IS THE SOLE PROPERTY OF VESTIL MANUFACTURING CO. ANY REPRODUCTION IN PART OR AS A WHOLE WITHOUT THE WRITTEN PERMISSION OF VESTIL MANUFACTURING CO. IS PROHIBITED.

REMOVE ALL BURRS AND SHARP EDGES		
CONCENTRIC	.006 TIR	.060 TIR
ANGLES	+/- 0° 30'	+/- 1° 0'
DECIMALS	x.xxx +/- .005 x.xx +/- .010 x.x +/- .025	+/- .015
FRACTIONS	+/- 1/32	+/- 1/16
TOLERANCE	MACHINE	WELDMENT

Vestil Manufacturing Co.

SCALE: NTS	APPROVED BY:	DRAWN BY: J.YOUNG
DATE: 06/30/11		SIZE: A
HDC2 CRUSHER ASSEMBLY PARTS LIST SHEET3		
MATERIAL:	DRAWING NUMBER:	REV:

FUNCTIONS TESTS AND INSPECTIONS:

⚠WARNING Only use the crusher if it passes each function test. If a malfunction(s) occurs, park the compactor in a safe location, tag it “Out-of-Service” and report the malfunction to authorized maintenance personnel. **DO NOT** use the HDC until it is restored to normal operating condition.

The following inspections and tests should be performed before towing or using the compactor. Inspect the listed components and test them to verify normal condition and function (see parts diagrams on p. 6-14):

1. Trailer frame – inspect frame for damage like cracked welds, bent or warped supports,
2. Trailer coupler (identified in FIG. 4) - should be clean and lubricated with grease;
3. Safety chains – links and hook should be undamaged and exhibit no signs of stretching, cracking or warping; before connecting the chains to the tow vehicle, cross the chains underneath the coupler.
4. Brake lights, wiring, and breakaway switch - no corrosion or exposed wires; connect the trailer to the tow vehicle and verify that the brake lights and turn signals on the trailer activate properly.
5. Hydraulic system & oil level – inspect all hydraulic lines for leaks. The reservoir should be at least half filled with oil. Two gauges (see Fig. 5A) are integrated into the reservoir to display the oil fill level. The oil level should register between the red and black horizontal lines in the gauge.
6. Gasoline motor - verify proper fluid levels and engine function according to the Briggs and Stratton “Operating and Maintenance Instructions” manual shipped with the unit.
7. Tires - check tire inflation and tread condition. If necessary, inflate the tires to match manufacturer guidelines. Tire over-inflation and under-inflation might cause the trailer to rock back and forth during transport, so be certain to match inflation pressure specifications displayed on the tires;
8. Stabilizing jacks (2) – jacks should be free of damage (corrosion, warping, and cracking, for example). Attach both stabilizing jacks to the trailer (see FIG. 8; See “Stabilizing Jacks” on p. 16) and extend the jacks by rotating the handles clockwise. Extend the jacks until the base of each jack solidly contacts the ground. Each jack should extend and retract smoothly; if a jack does not, unfasten it from the trailer, fully extend it, and apply lubricant to the extended portion.
9. Door sensor switch function (see FIG. 6) – open the door to the drum enclosure, put a piece of electrical tape over one side of the switch, close and latch the door, and then try to activate the crusher.
10. Siren and amber light – tilt the crusher to the

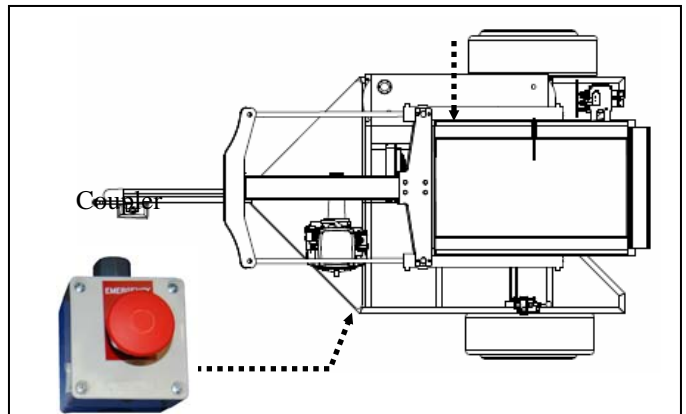

FIG. 4: Emergency Stops (dashed arrows)



FIG. 5A: Right side view. Arrows indicate locations of oil level/fuel gauges (2). The oil level should be between the red and black lines.

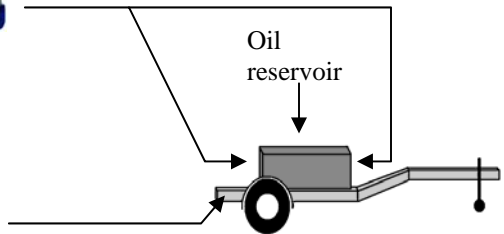

FIG. 5B: A stabilizing jack mount is present on both the left and the right side of the trailer. The diagram shows the location of only the right side mount.

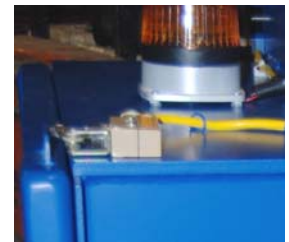

FIG. 6: Open the door to the drum enclosure to separate the 2 sides of the door switch. Cover the contact surfaces of both sides with electrical tape, close and latch the door, and then try to lower the crusher ram.

upright/vertical position by pushing the compactor orientation control lever forward (see Fig. 7). Both the siren and the amber light should automatically activate.

11. Cylinders and cylinder connection points – inspect all cylinders for signs of damage such as bending or cracking. Inspect the cylinder attachment points, including retaining pins for warps and cracks.
12. Emergency stop switches – start the motor & let it run for ~10 seconds; then press 1 of the 2 emergency stop buttons, which should immediately stop the motor. Pull the red button upwards to reset the switch. Restart the motor; then repeat the process, but this time press the other emergency stop switch.

PREPARING COMPACTOR FOR OPERATION

Attach stabilizing jacks: as shipped, the jacks are attached to the storage couplings as shown in FIG. 8 “Stabilizing jacks storage and use” below.

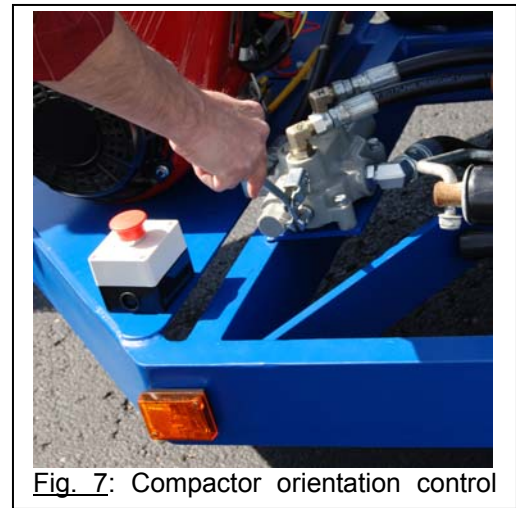

Fig. 7: Compactor orientation control

FIG. 8: Stabilizing jacks storage and use

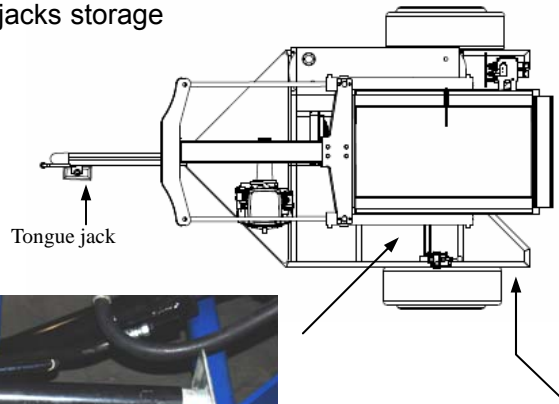

FIG 8A: Disconnect stabilizing jacks from storage couplings; remove the retaining pins; then pull the jacks upwardly to uncouple them from the trailer.

1. Slide each jack onto a jack mount (1 behind each wheel) and align the pin holes.
2. Install pins through the holes on the jack frame mount
3. Crank the jack handle clockwise until the feet firmly contact the ground.
4. Pivot tongue jack to vertical position.
5. Lower the jack until it firmly contacts the ground.



FIG 8B: Fasten the jacks to the jack mounts with the retaining pins.



FIG 8C: Tongue jack

OPERATION

NOTE: Information about the motor appears in a separate manual titled "Operating & Maintenance Instructions". A copy of the manual should be enclosed within a plastic sleeve attached to the motor. Read the manual before using the compactor for the first time, because it identifies motor components, describes motor operation, and provides itemized maintenance recommendations.

1. Start motor: as long as the battery maintains sufficient charge, the key starter will start the motor (FIG. 9, solid white arrow). Turn the key clockwise to start the motor. If the engine does not start by key, use the auxiliary pull cord (FIG. 9, dashed black arrow).

2. Put compactor in vertical/use position: press the compactor orientation lever (see FIG. 7) forward to pivot the compactor to the vertical/use position. If the compactor is not fully vertical, the unit will not operate.

3. Load the compactor:

[NOTE ABOUT HYDRAULIC OIL TEMPERATURE: the hydraulic oil will become hot during operation. If you crush several drums in rapid succession, the oil temperature will rise rapidly. When the temperature reaches 130°F (~54°C), a cooling fan will activate. Avoid contact with the oil reservoir until the oil cools following operation.]

- a. Cycle the compactor a minimum of 3 times to warm the hydraulic fluid. Cylinders might not extend or retract fully until oil is warm. In cooler environments, additional cycling might be necessary.
- b. Center an empty drum beneath the platen inside the chamber (maximum size = 55 gallon drum). To crush non-ribbed drums, first dent the side wall of the drum in several places. The compactor is designed to crush standard *ribbed* steel drums of 55 gallon size or smaller. **DO NOT** use the crusher to compact smooth-walled drums, i.e. drums that lack ribs. The crusher can be used to compact (standard ribbed) steel drums that contain soft materials. When loading the crusher, always apply these suggestions:
 - i. Before using the compactor, confirm that the platen is properly installed;
 - ii. Carefully center the material/item to be crushed under the platen, because an offset or uneven load might damage the cylinder rod;
 - iii. **DO NOT** fill drums with scrap metal, paint cans, etc. which will exceed the crushing capacity of the unit and significantly damage the crusher.

NOTE: The crusher is designed to compact standard, ribbed steel drums. However, the crusher might not compact a particular drum. It is also possible that the crusher might sustain minor damage during the compaction process.

- c. Press the foot pedal down to activate the compactor (see FIG. 10).

Sequence of Operation: The direction of the travel of the compactor ram/platen is determined by its starting position: if it is fully raised, the platen moves down to crush a drum. Otherwise, the cylinder will raise the platen all the way to its starting/home position, at which point the power unit will turn off. Pressing the foot pedal again will cause the platen to move downward. The operator must hold the button for a few seconds to latch the circuit.

When the crusher is in its "home" position and the cycle starts, the cylinder pushes the platen down onto (or into) the drum. To provide a short cycle time, both sections of the pump drive oil to the cylinder until the cylinder pressure reaches approximately 1000 PSI. At that time, the higher-displacement section recycles oil to the reservoir while the low-displacement, high-



FIG. 6: Gasoline motor

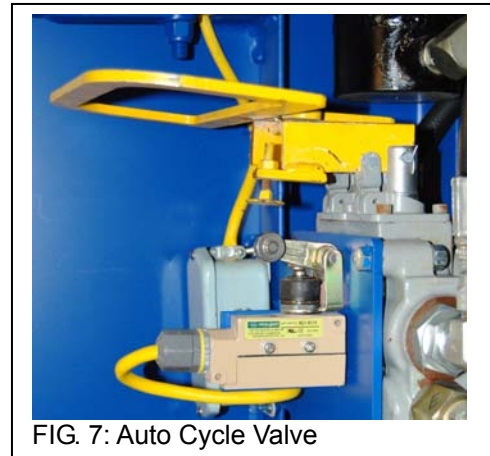

FIG. 7: Auto Cycle Valve

pressure section continues to pump oil to the cylinder, i.e. a typical High-Low circuit.

As the platen crushes or compacts the drum to a height of about 6 inches, the cylinder pressure increases until it reaches the set-point of the particular pressure switch. The valve shifts to center and a timer activates to control the period of decompression. Once the period ends, the directional valve shifts and reverses the direction of oil flow to the cylinder. Reversing the flow of oil raises the platen to its starting, or "home" position. When the cylinder returns the platen all the way to the top of the cabinet, the power unit turns off. At this point, the door can be opened to remove the compacted drum.

If you must stop the unit at any point during its cycle, press one of the red emergency stop buttons located as indicated in FIG. 4. The emergency stop buttons kill the motor which prevents the unit from cycling further. To return the platen to its starting ("home") position, pull the emergency stop button out to release it and press the foot pedal (cycle start button). This causes the platen to return to the starting position. To cycle the unit again, press the foot pedal.

4. Return the compactor to the horizontal/travel position:
 - a. Pull the lever (see FIG. 7) toward you until the compactor returns to the transport position; then turn off the engine.
 - b. Return the stabilizing jacks to the travel mounts (see Fig. 8A). Place pins through jack mounts to secure jacks to the trailer.
5. Put unit into transport condition:
 - a. Attach the hitch to a 2 inch ball on the tow vehicle
 - b. Connect safety chains to anchor points on tow vehicle
 - c. Connect wire harnesses

Tongue jack needs to be in the up position for travel (Fig. 6).

Filling hydraulic oil:

1. Remove cap (Fig. 11).
2. Fill to the required level. DO NOT use brake fluid or jack oil in the hydraulic system. If oil is needed, use an anti-wear hydraulic oil with a viscosity grade of 150 SUS at 100°F, (ISO 32 @ 40°C), or a non-synthetic transmission fluid.

BATTERY REPLACEMENT:

1. Disconnect wire harness from vehicle.
2. Remove positive and (+) negative (–) cables from the battery.
3. Replace battery with identical battery of equal specifications.

RESPONSIBILITIES OF OWNERS/USERS

The owner/end-user should inspect and maintain this product according to the guidelines in this manual. Any unit not in normal operating condition should immediately be removed from service and remain out-of-service until it is returned to normal operating condition. Unsafe conditions include, but are not limited to, the following: excessive hydraulic oil or air leakage, missing pins, or fasteners, any cracked or deformed structural members, cut or frayed hydraulic, electric or air lines, and damaged controls or safety devices.



Fig. 11: Hydraulic Oil Fill Cap

INSPECTIONS & MAINTENANCE INSTRUCTIONS

[EMPTY THE CRUSHER BEFORE INSPECTING OR PERFORMING MAINTENANCE ON IT.]

(A) Before each use, inspect the crusher and remove it from service if any of the following issues are observed:

- 1.) Frayed wires;
- 2.) Oil leaks;
- 3.) Pinched or chafed hoses, loose fittings;
- 4.) Structural deformation of frame;
- 5.) Unusual noise or binding

(B) Monthly Inspections:

- 1.) Check oil level. Oil should be 2" to 2½" below the top of the tank with the cylinder in the fully retracted position. Add as necessary.
- 2.) Check for oil leaks.
- 3.) Check for worn or damaged hydraulic hoses, electrical wires, and cords. Repair as necessary.
- 4.) Cycle the crusher and listen for unusual noise.
- 5.) Make sure all warning labels are readable and in place according to the diagram on p. 20.
- 6.) Remove dirt and debris.

(C) Yearly Inspection:

Change the hydraulic oil at least once per year. However, because the oil should be changed as soon as it darkens, looks milky, or becomes gritty, oil changes might be required more frequently than every 12 months.

- After draining the oil from the reservoir, flush the reservoir before refilling it.
- If the oil looks milky, water is present and the oil should be changed immediately.
- Recommended hydraulic oil: Purity ISO AW-32 Hydraulic fluid or equal.

(D) Changing tires: (compactor must be in the horizontal/transport position)

1. Attach both stabilizing jacks to the jack mounts.
2. Raise the rear of the unit up so the tire is off the ground.
3. Remove lug nuts.
4. Replace Tire.
5. Re-install tire with lug nuts.
6. Torque to required specifications.

(E) Filling hydraulic oil:

1. Remove cap (Fig. 11).
2. Fill to the required level. DO NOT use brake fluid or jack oil in the hydraulic system. If oil is needed, use an anti-wear hydraulic oil with a viscosity grade of 150 SUS at 100°F, (ISO 32 @ 40°C), or a non-synthetic transmission fluid.

(F) Battery replacement:

1. Disconnect wire harness from vehicle.
2. Remove positive and (+) negative (−) cables from the battery.
3. Replace battery with identical battery of equal specifications.

HDC-900-GPT

Front

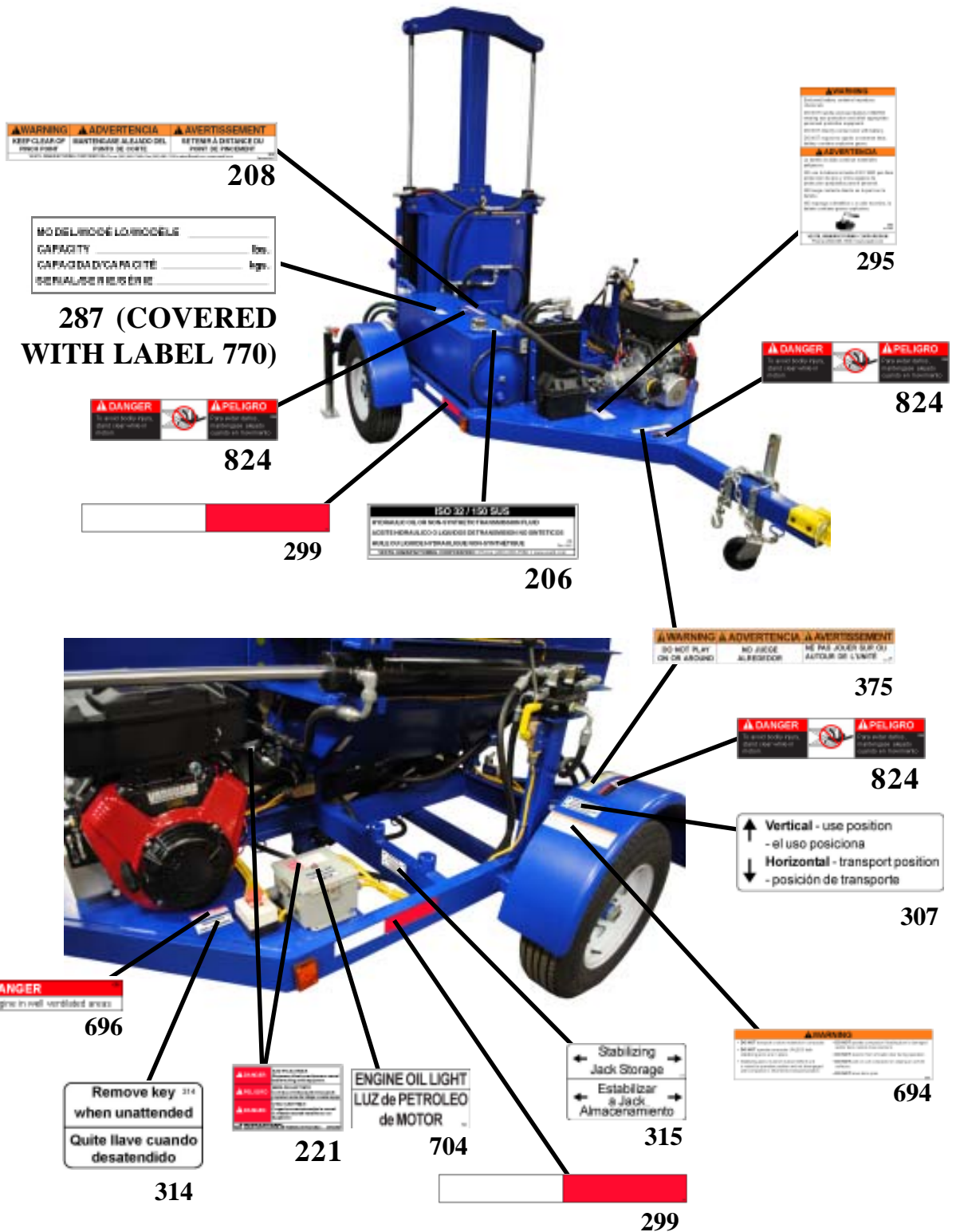

GAS POWERED DRUM CRUSHER

HDC-900-GPT

Back

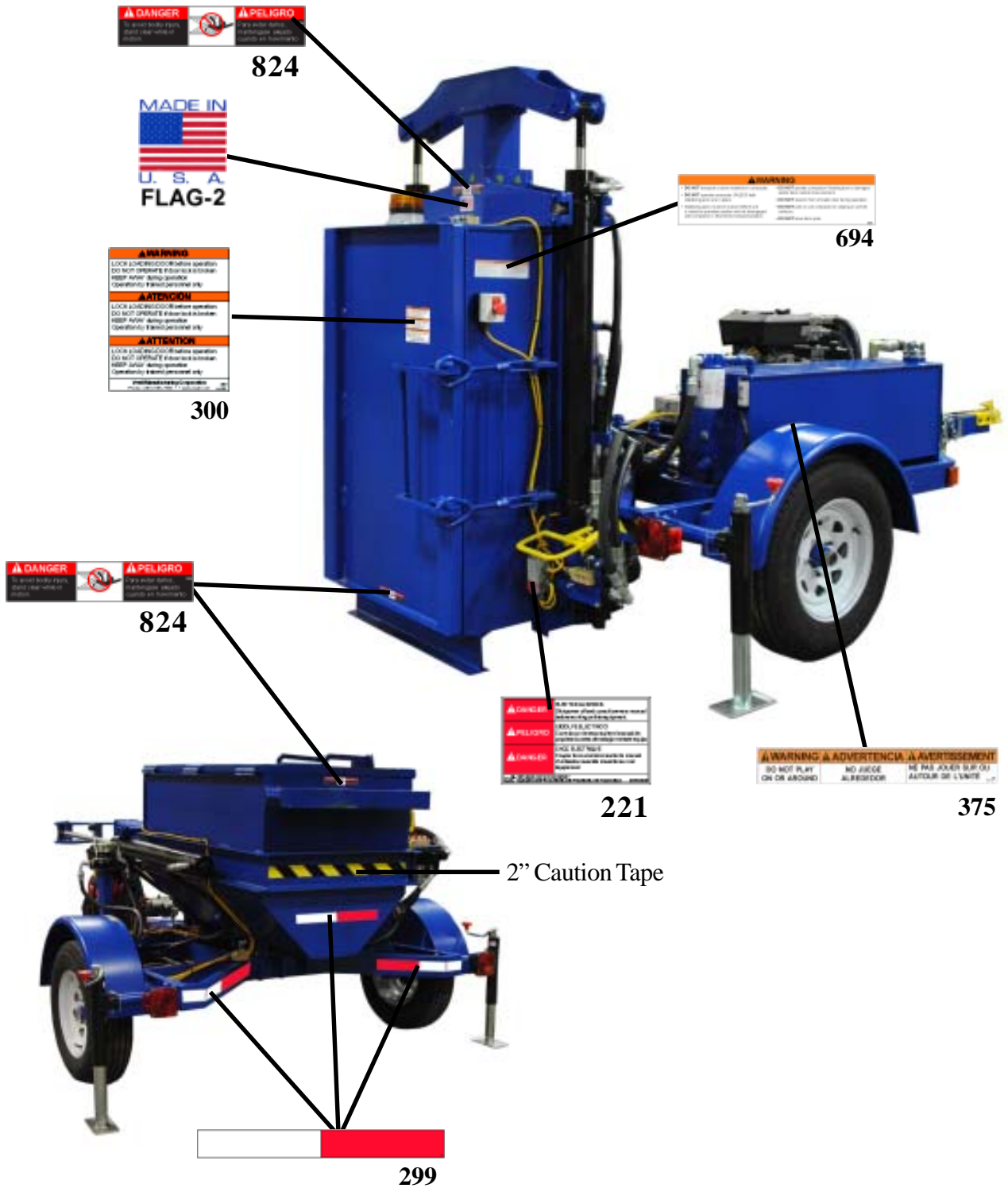

GAS POWERED DRUM CRUSHER

LIMITED WARRANTY

Vestil Manufacturing Corporation (“Vestil”) warrants this HDC-900 (excluding “Washdown” model HDC-900-WD, which is covered by a separate warranty) to be free of defects in material and workmanship during the warranty period. Our warranty obligation is to provide a replacement for a defective original part if the part is covered by the warranty, after we receive a proper request from the warrantee (you) for warranty service.

Who may request service?

Only a warrantee may request service. *You are a warrantee if* you purchased the product from Vestil or from an authorized distributor AND Vestil has been fully paid.

What is an “original part”?

An original part is a part used to make the product as shipped to the warrantee.

What is a “proper request”?

A request for warranty service is proper if Vestil receives: 1) a photocopy of the Customer Invoice that displays the shipping date; AND 2) a written request for warranty service including your name and phone number. Send requests by any of the following methods:

<u>Mail</u>	<u>Fax</u>	<u>Email</u>
Vestil Manufacturing Corporation 2999 North Wayne Street, PO Box 507 Angola, IN 46703	(260) 665-1339 <u>Phone</u> (260) 665-7586	sales@vestil.com

In the written request, list the parts believed to be defective and include the address where replacements should be delivered.

What is covered under the warranty?

After Vestil receives your request for warranty service, an authorized representative will contact you to determine whether your claim is covered by the warranty. Before providing warranty service, Vestil may require you to send the entire product, or just the defective part or parts, to its facility in Angola, IN. The warranty covers defects in the following *original* dynamic components: motors, hydraulic pumps, electronic controllers, switches and cylinders. It also covers defects in *original* parts that wear under normal usage conditions (“wearing parts”): bearings, hoses, wheels, seals, brushes, batteries, and the battery charger.

How long is the warranty period?

The warranty period for original components is 1 year. The warranty period begins on the date when Vestil ships the product to the warrantee. If the product was purchased from an authorized distributor, the period begins when the distributor ships the product. Vestil may extend the warranty period for products shipped from authorized distributors by *up to* 30 days to account for shipping time.

If a defective part is covered by the warranty, what will Vestil do to correct the problem?

Vestil will provide an appropriate replacement for any *covered* part. An authorized representative of Vestil will contact you to discuss your claim.

What is not covered by the warranty?

1. Labor;
2. Freight;
3. Occurrence of any of the following, which automatically voids the warranty:
 - Product misuse;
 - Negligent operation or repair;
 - Corrosion or use in corrosive conditions;
 - Inadequate or improper maintenance;
 - Damage sustained during shipping;
 - Accidents involving the product;
 - Unauthorized modifications: DO NOT modify the product IN ANY WAY without first receiving written authorization from Vestil. Modification(s) might make the product unsafe to use or might cause excessive and/or abnormal wear.

Do any other warranties apply to the product?

Vestil Manufacturing Corp. makes no other express warranties. All implied warranties are disclaimed to the extent allowed by law. Any implied warranty not disclaimed is limited in scope to the terms of this Limited Warranty.

